

SA 8 E

Dimensions

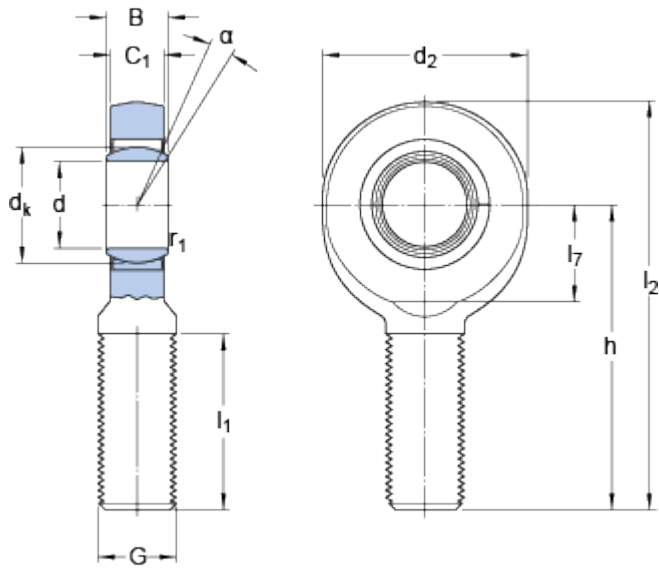

| | | | |
|----------------|------|-----|----|
| d | | 8 | mm |
| d ₂ | max. | 25 | mm |
| B | | 8 | mm |
| G | | M 8 | |
| C ₁ | max. | 6.5 | mm |
| h | | 42 | mm |
| α | | 15 | ° |
| d _k | | 13 | mm |
| l ₁ | min. | 21 | mm |
| l ₂ | max. | 56 | mm |
| l ₇ | min. | 11 | mm |
| r ₁ | min. | 0.3 | mm |

Calculation data

| | | | |
|------------------------------|----------------|------|-------------------|
| Basic dynamic load rating | C | 5.5 | kN |
| Basic static load rating | C ₀ | 12.9 | kN |
| Specific dynamic load factor | K | 100 | N/mm ² |
| Material constant | K _M | 330 | |

Mass

| | | |
|--------------|-------|----|
| Mass rod end | 0.029 | kg |
|--------------|-------|----|